

Please check the examination details below before entering your candidate information

Candidate surname

Other names

Centre Number

Candidate Number

--	--	--	--	--

--	--	--	--

Pearson Edexcel International GCSE (9–1)

Time 1 hour 15 minutes

Paper
reference

4PH1/2PR

Physics

UNIT: 4PH1

PAPER: 2PR

You must have:

Ruler, calculator

Total Marks

Instructions

- Use **black** ink or ball-point pen.
- **Fill in the boxes** at the top of this page with your name, centre number and candidate number.
- Answer **all** questions.
- Answer the questions in the spaces provided
– *there may be more space than you need.*
- Show all steps in any calculations and state the units.

Information

- The total mark for this paper is 70.
- The marks for **each** question are shown in brackets
– *use this as a guide as to how much time to spend on each question.*

Advice

- Read each question carefully before you start to answer it.
- Write your answers neatly and in good English.
- Try to answer every question.
- Check your answers if you have time at the end.

Turn over ►

P70714A

©2022 Pearson Education Ltd.

L:1/1/1/1/



Pearson

FORMULAE

<https://britishstudentroom-b430a.web.app/>

You may find the following formulae useful.

energy transferred = current \times voltage \times time

$$E = I \times V \times t$$

$$\text{frequency} = \frac{1}{\text{time period}}$$

$$f = \frac{1}{T}$$

$$\text{power} = \frac{\text{work done}}{\text{time taken}}$$

$$P = \frac{W}{t}$$

$$\text{power} = \frac{\text{energy transferred}}{\text{time taken}}$$

$$P = \frac{W}{t}$$

$$\text{orbital speed} = \frac{2\pi \times \text{orbital radius}}{\text{time period}}$$

$$v = \frac{2 \times \pi \times r}{T}$$

(final speed)² = (initial speed)² + (2 \times acceleration \times distance moved)

$$v^2 = u^2 + (2 \times a \times s)$$

pressure \times volume = constant

$$p_1 \times V_1 = p_2 \times V_2$$

$$\frac{\text{pressure}}{\text{temperature}} = \text{constant}$$

$$\frac{p_1}{T_1} = \frac{p_2}{T_2}$$

$$\text{force} = \frac{\text{change in momentum}}{\text{time taken}}$$

$$F = \frac{(mv - mu)}{t}$$

$$\frac{\text{change of wavelength}}{\text{wavelength}} = \frac{\text{velocity of a galaxy}}{\text{speed of light}}$$

$$\frac{\lambda - \lambda_0}{\lambda_0} = \frac{\Delta\lambda}{\lambda_0} = \frac{v}{c}$$

change in thermal energy = mass \times specific heat capacity \times change in temperature

$$\Delta Q = m \times c \times \Delta T$$

Where necessary, assume the acceleration of free fall, $g = 10 \text{ m/s}^2$.

DO NOT WRITE IN THIS AREA

DO NOT WRITE IN THIS AREA

DO NOT WRITE IN THIS AREA



Answer ALL questions.

<https://britishstudent.com/uk/10a.web.app/>

Some questions must be answered with a cross in a box ☒. If you change your mind about an answer, put a line through the box ☒ and then mark your new answer with a cross ☒.

1 (a) The table lists four methods of generating electricity and four energy stores.

Method of generating electricity	Energy store			
	Thermal	Gravitational potential	Kinetic	Chemical
geothermal power station				
hydroelectric power station				
petrol generator				
wind turbine				

The energy store of the initial energy resource decreases when electricity is being generated.

- (i) Complete the table by placing one tick (✓) in each row to show which energy store decreases. (4)
- (ii) State which method of generating electricity in the table does **not** use a renewable energy resource. (1)

(b) State two disadvantages of using wind turbines to generate electricity. (2)

1

2

(Total for Question 1 = 7 marks)

DO NOT WRITE IN THIS AREA

DO NOT WRITE IN THIS AREA

DO NOT WRITE IN THIS AREA



P 7 0 7 1 4 A 0 3 2 4

2 Cricket is a sport played with bats and balls.

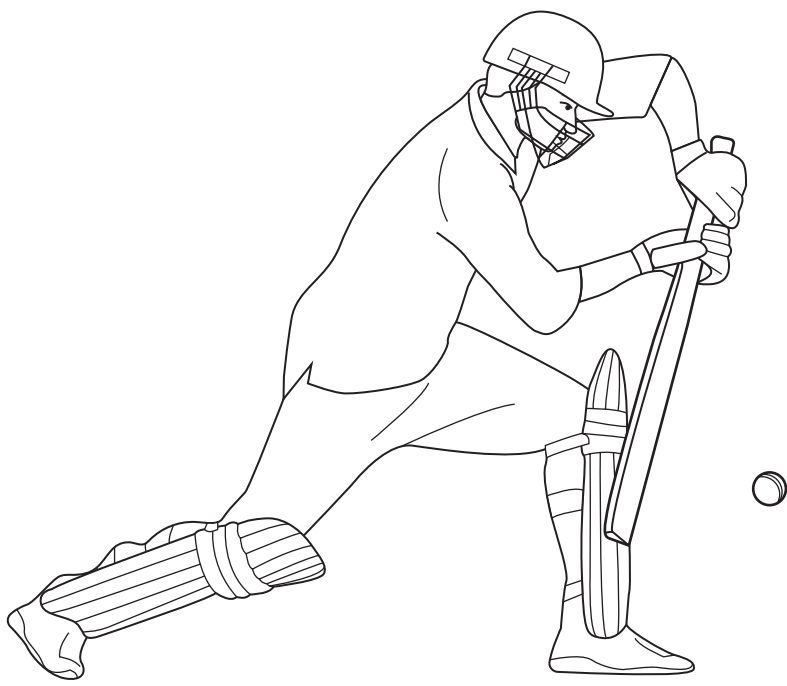

DO NOT WRITE IN THIS AREA

DO NOT WRITE IN THIS AREA

DO NOT WRITE IN THIS AREA

- (a) (i) A cricket player hits a ball with a bat. Before the ball is hit, it is moving to the **left** with a momentum of 4.2 kg m/s .
The bat is in contact with the ball for 0.012 s .
After the ball is hit, it moves to the **right** with a momentum of 6.7 kg m/s .
Calculate the mean force the bat exerts on the ball and state the direction of the force.

(3)

mean force = N
direction

- (ii) State the magnitude and direction of the mean force the **ball** exerts on the **bat**.

(1)

magnitude of mean force = N
direction of force



(b) The cricket player wears padded protective equipment.

This protective equipment reduces the risk of injury to the player if they are struck by the cricket ball.

Explain how this protective equipment reduces the risk of injury to the player.

Use ideas about momentum in your answer.

(3)

.....

.....

.....

.....

.....

.....

.....

.....

.....

.....

.....

.....

.....

.....

.....

.....

.....

.....

.....

.....

.....

.....

.....

(Total for Question 2 = 7 marks)

DO NOT WRITE IN THIS AREA

DO NOT WRITE IN THIS AREA

DO NOT WRITE IN THIS AREA



3 Two students do an experiment to measure the speed of sound in air.
They use two blocks of wood that make a loud noise when hit together.
They do their experiment outside in a wide-open space.

(a) Describe how the students should use their equipment to measure the speed of sound in air.

You may draw a diagram to support your answer.

(5)

.....

.....

.....

.....

.....

.....

.....

.....

.....

.....

.....

.....

.....

.....

.....

.....

.....

.....

.....

.....

.....

.....

.....

DO NOT WRITE IN THIS AREA

DO NOT WRITE IN THIS AREA

DO NOT WRITE IN THIS AREA



(b) The table shows the students' results.

Distance in m	Time in s			
	Trial 1	Trial 2	Trial 3	Mean
50	0.46	0.35	0.49	0.43
100	0.50	0.38	0.62	0.50
150	0.42	0.64	0.57	0.54
200	0.68	0.59	0.60	0.62
250	0.58	0.79	0.75	0.71
300	0.90	0.86	0.84	

(i) Calculate the mean time for the last row in the table. (2)

mean time = s

(ii) The students think that some of their time readings are anomalous.
State how the students should deal with these anomalous readings. (1)

.....
.....

(iii) Explain which distance in the table is likely to give the most accurate value for the speed of sound in air. (2)

.....
.....
.....
.....
.....
.....

(Total for Question 3 = 10 marks)

DO NOT WRITE IN THIS AREA

DO NOT WRITE IN THIS AREA

DO NOT WRITE IN THIS AREA



4 A racing car uses an engine and an electric motor to power its wheels.



(Source: Jens Mommens/Shutterstock)

DO NOT WRITE IN THIS AREA

DO NOT WRITE IN THIS AREA

DO NOT WRITE IN THIS AREA

(a) The electric motor can only operate at maximum power for part of each lap of the race.

The electric motor has a maximum power output of $1.2 \times 10^5 \text{ W}$.

The electric motor transfers $4.0 \times 10^6 \text{ J}$ of energy when it operates at maximum power.

Calculate the amount of time the electric motor can operate at maximum power.

(3)

time = s



(b) The diagram shows a simplified view of a direct current (d.c.) electric motor.

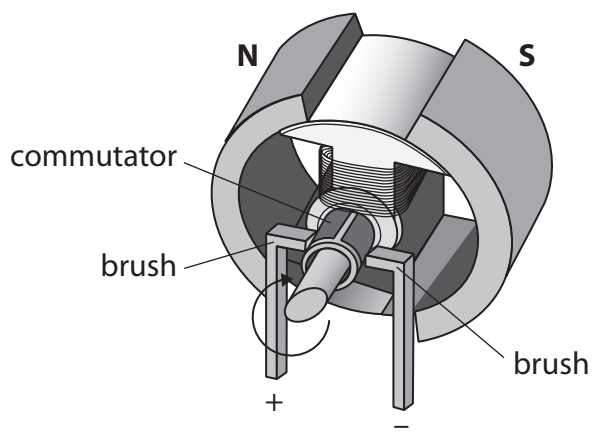

(i) State what is meant by the term **direct current**. (1)

.....

.....

(ii) Explain the purpose of the brushes and the commutator in the d.c. motor. (3)

.....

.....

.....

.....

.....

.....

DO NOT WRITE IN THIS AREA

DO NOT WRITE IN THIS AREA

DO NOT WRITE IN THIS AREA



(c) The electric motor in the racing car can also be used as a generator to charge a battery pack. It is known as a motor generator unit (MGU).

The rotating wheels of the car cause the magnets in the MGU to spin near a coil of wire.

This induces a current in the coil when the coil is connected to the battery pack.

(i) Name the energy store of the battery pack that increases when the battery pack is being charged. (1)

(ii) Explain why the kinetic energy store of the car must decrease when the MGU charges the battery pack. (3)

(Total for Question 4 = 11 marks)



DO NOT WRITE IN THIS AREA

DO NOT WRITE IN THIS AREA

DO NOT WRITE IN THIS AREA

BLANK PAGE



5 This question is about nuclear fusion.

(a) The incomplete nuclear equation shows the fusion of two isotopes of hydrogen.



(i) Identify particle X in the nuclear equation.

(1)

(ii) Each fusion reaction releases approximately 3×10^{-12} J of energy.

Estimate how many reactions are needed to produce 1 J of energy.

Give your answer to 1 significant figure.

(2)

number of reactions =

(iii) Explain why this fusion reaction will only happen at high temperature and high pressure.

(3)

.....

.....

.....

.....

.....

.....



(b) A tokamak is an experimental nuclear fusion reactor.

Strong magnetic fields are used to contain the reactants inside the tokamak.

- (i) The diagram shows a positively charged hydrogen nucleus in a uniform magnetic field directed out of the page.

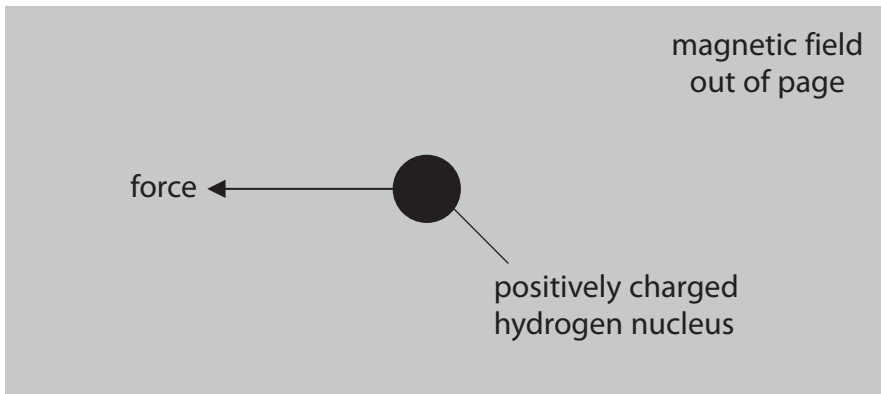

The nucleus experiences a force acting to the left because of the magnetic field.

Deduce how the nucleus must behave to experience this force.

(2)

.....

.....

.....

.....

- (ii) Suggest how engineers working on the tokamak could increase the force on the nucleus.

(1)

.....

.....

(Total for Question 5 = 9 marks)

DO NOT WRITE IN THIS AREA

DO NOT WRITE IN THIS AREA

DO NOT WRITE IN THIS AREA



6 (a) State what is meant by the astronomical term **galaxy**.

.....

.....

DO NOT WRITE IN THIS AREA

DO NOT WRITE IN THIS AREA

DO NOT WRITE IN THIS AREA

(b) Which of these is a large collection of billions of galaxies?

(1)

- A** a nebula
- B** a red giant
- C** the solar system
- D** the universe

(c) Hydrogen is an element that can emit visible light waves.

The table shows the wavelength of one of these waves when detected from a laboratory sample of hydrogen and when detected from the hydrogen in two different galaxies.

The detected wavelengths from the galaxies are different from the detected wavelength from the laboratory sample because of the Doppler effect.

	Wavelength in nm
Laboratory sample	656.45
Galaxy A	656.21
Galaxy B	657.81



- (i) Galaxy A and galaxy B are both moving relative to Earth.
Compare the motions of galaxy A and galaxy B relative to Earth.

(3)

<https://britishstudentroom-b430a.web.app/>

- (ii) Use data from the table to calculate the speed of galaxy B relative to Earth.

[speed of light, $c = 3.0 \times 10^8$ m/s]

(4)

speed = m/s

(Total for Question 6 = 9 marks)

DO NOT WRITE IN THIS AREA

DO NOT WRITE IN THIS AREA

DO NOT WRITE IN THIS AREA



7 A student investigates the rate of cooling of water in a beaker.

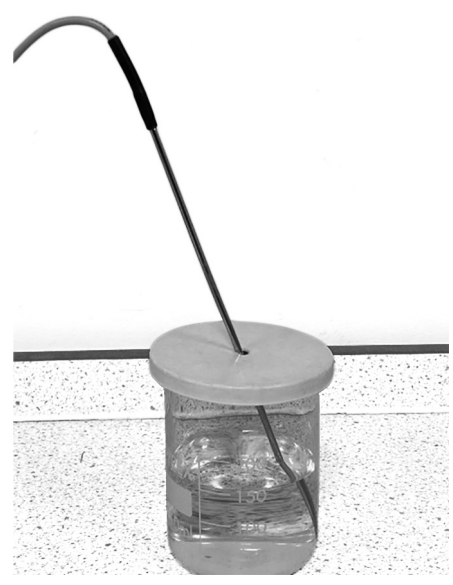

DO NOT WRITE IN THIS AREA

DO NOT WRITE IN THIS AREA

DO NOT WRITE IN THIS AREA

The student pours boiling water into a beaker and monitors the temperature of the water for a period of time.

The graph shows the student's results.

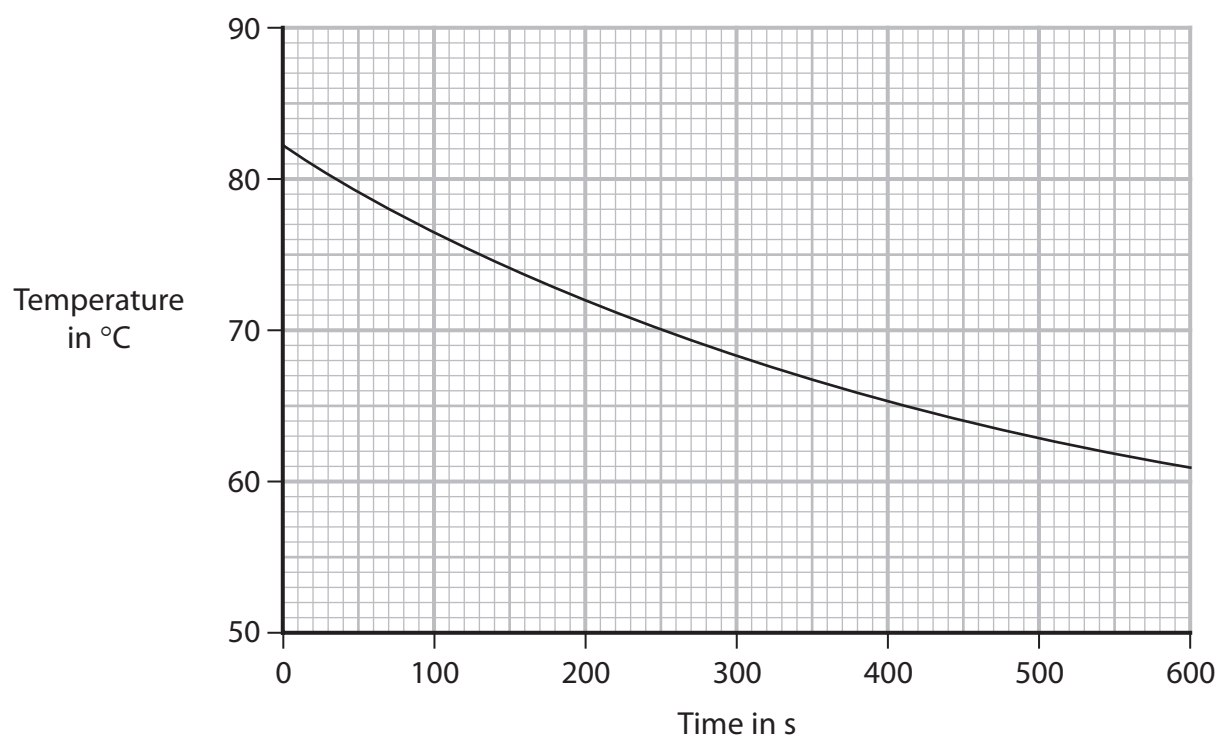

DO NOT WRITE IN THIS AREA

DO NOT WRITE IN THIS AREA

DO NOT WRITE IN THIS AREA

(a) The rate of cooling is represented by the gradient of the graph and is measured in $^{\circ}\text{C}/\text{s}$.

By drawing a tangent to the curve, determine the rate of cooling of the water at 70°C .

(4)

rate of cooling = $^{\circ}\text{C}/\text{s}$

(b) The student repeats the investigation with the same beaker wrapped in woollen insulation.



Sketch another line on the graph to show the expected results when the beaker is wrapped in woollen insulation.

Assume that the starting temperature of the water is 82°C .

(2)

(Total for Question 7 = 6 marks)



8 Diagram 1 shows a machine used for demonstrating electrostatics.

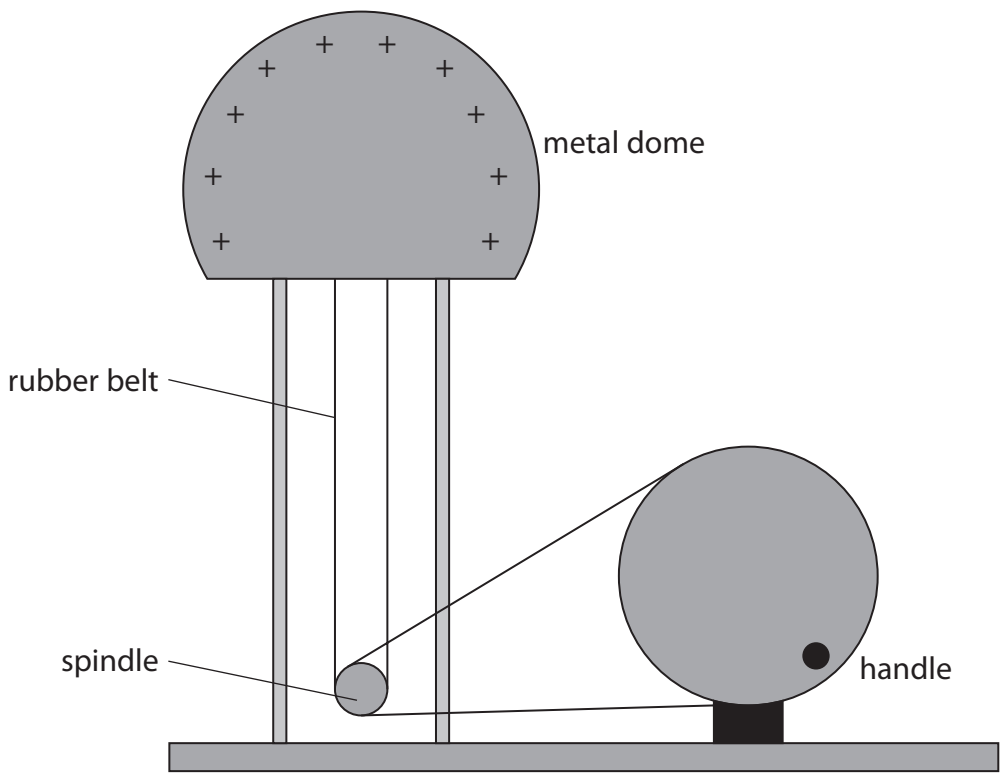

Diagram 1

- (a) When the handle is turned, the dome becomes positively charged.
 - (i) In terms of electron movement, give a reason why the metal dome becomes positively charged.

(1)

.....

.....

DO NOT WRITE IN THIS AREA

DO NOT WRITE IN THIS AREA

DO NOT WRITE IN THIS AREA



- (ii) When the handle is turned for 15 s the dome gains 0.50 J of energy in its electrostatic store as it becomes charged.

The voltage between the dome and the earth is 120 kV.

Calculate the mean charging current during this time.

(3)

mean charging current = A

<https://britishstudentroom-b430a.web.app/>

DO NOT WRITE IN THIS AREA

DO NOT WRITE IN THIS AREA

DO NOT WRITE IN THIS AREA



(b) The metal dome is discharged.

A thin metal case is then placed on top of the metal dome, as shown in Diagram 2.

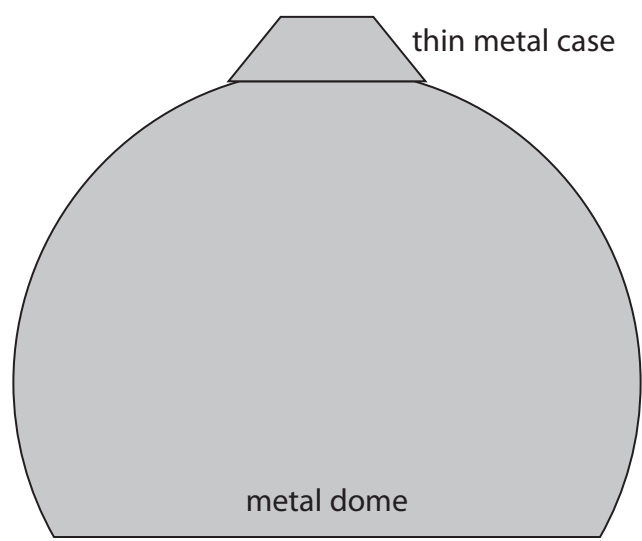

Diagram 2

(i) When the handle is turned, the thin metal case moves upwards away from the dome.

Explain why the thin metal case starts to move upwards.

(3)

.....

.....

.....

.....

.....

.....



(ii) Explain why the metal case reaches a maximum height above the metal dome.

<https://britishstudentroom-b430a.web.app/>

DO NOT WRITE IN THIS AREA

DO NOT WRITE IN THIS AREA

DO NOT WRITE IN THIS AREA

(Total for Question 8 = 11 marks)

TOTAL FOR PAPER = 70 MARKS



P 7 0 7 1 4 A 0 2 1 2 4

DO NOT WRITE IN THIS AREA

DO NOT WRITE IN THIS AREA

DO NOT WRITE IN THIS AREA

BLANK PAGE



DO NOT WRITE IN THIS AREA

DO NOT WRITE IN THIS AREA

DO NOT WRITE IN THIS AREA

BLANK PAGE



DO NOT WRITE IN THIS AREA

DO NOT WRITE IN THIS AREA

DO NOT WRITE IN THIS AREA

BLANK PAGE

