

Please check the examination details below before entering your candidate information

Candidate surname

Other names

Centre Number

Candidate Number

--	--	--	--	--

--	--	--	--

Pearson Edexcel International GCSE

Time 1 hour 30 minutes

Paper
reference

4MB1/01R

Mathematics B PAPER 1R



You must have: Ruler graduated in centimetres and millimetres, protractor, pair of compasses, pen, HB pencil, eraser, calculator. Tracing paper may be used.

Total Marks

Instructions

- Use **black** ink or ball-point pen.
- **Fill in the boxes** at the top of this page with your name, centre number and candidate number.
- Answer **all** questions.
- Answer the questions in the spaces provided – *there may be more space than you need.*
- **Calculators may be used.**

Information

- The total mark for this paper is 100.
- The marks for **each** question are shown in brackets – *use this as a guide as to how much time to spend on each question.*

Advice

- Read each question carefully before you start to answer it.
- Check your answers if you have time at the end.
- Without sufficient working, correct answers may be awarded no marks.

Turn over ►

P72478A

©2023 Pearson Education Ltd.

J:1/1/1/1/



Pearson

Answer ALL TWENTY SIX questions.

Write your answers in the spaces provided.

You must write down all the stages in your working.

<https://britishstudentroom.com/>

DO NOT WRITE IN THIS AREA

DO NOT WRITE IN THIS AREA

DO NOT WRITE IN THIS AREA

- 1 Write 48 seconds as a fraction of 1 day.
Give your answer in its simplest form.

.....

(Total for Question 1 is 2 marks)

- 2 Here are the numbers of items that the last 9 people who visited a shop bought.

6 1 13 20 2 4 14 11 20

Find the median of these numbers of items.

.....

(Total for Question 2 is 2 marks)



DO NOT WRITE IN THIS AREA

DO NOT WRITE IN THIS AREA

DO NOT WRITE IN THIS AREA

3 Write down a formula for the n th term of the sequence.

7 11 15 19 23

.....
(Total for Question 3 is 2 marks)

4 Simplify fully $(125a^9)^{\frac{2}{3}}$

.....
(Total for Question 4 is 2 marks)

5 Given that $y = 21x^2 - \frac{8}{x}$

find $\frac{dy}{dx}$

$\frac{dy}{dx} =$

(Total for Question 5 is 2 marks)



6

$$A = 2^3 \times 3^4 \times 5^3 \times 11$$

$$B = 2^2 \times 3^3 \times 5^4$$

Find the lowest common multiple (LCM) of $2A$ and $7B$
Give your answer as a product of prime factors.

.....
(Total for Question 6 is 2 marks)

7 Without using a calculator, and showing all your working, evaluate

$$3\frac{2}{3} + 2\frac{4}{5}$$

Give your answer as a mixed number in its simplest form.

.....
(Total for Question 7 is 3 marks)



DO NOT WRITE IN THIS AREA

DO NOT WRITE IN THIS AREA

DO NOT WRITE IN THIS AREA

8 A farmer keeps cows, pigs and sheep.

The ratio of the number of cows he keeps to the number of pigs he keeps is 2 : 3

The ratio of the number of pigs he keeps to the number of sheep he keeps is 7 : 11

The farmer keeps 42 cows.

Work out the number of sheep the farmer keeps.

.....
(Total for Question 8 is 3 marks)

9 Solve $3(2 - x)^2 - 75 = 0$

Show clear algebraic working.

$x =$

(Total for Question 9 is 3 marks)



P 7 2 4 7 8 A 0 5 2 4

10 Simplify $\frac{7}{4x} + \frac{8}{3x} - \frac{2}{5x}$

Give your answer in its simplest form.

.....
(Total for Question 10 is 3 marks)

11 $A = \frac{w - x}{y}$

- $w = 21.7$ to one decimal place
- $x = 12$ to the nearest whole number
- $y = 20$ to the nearest ten

Find the lower bound for the value of A
Show your working clearly.

.....
(Total for Question 11 is 3 marks)

DO NOT WRITE IN THIS AREA

DO NOT WRITE IN THIS AREA

DO NOT WRITE IN THIS AREA



DO NOT WRITE IN THIS AREA

DO NOT WRITE IN THIS AREA

DO NOT WRITE IN THIS AREA

12 M varies inversely as the cube of p

$$M = 0.8 \text{ when } p = 25$$

Find a formula for M in terms of p

.....
(Total for Question 12 is 3 marks)

13 Solve

$$\frac{x + 3}{7} + \frac{2x - 1}{4} = 5$$

Show clear algebraic working.

$x =$

(Total for Question 13 is 3 marks)



14 The diagram shows a square piece of card from which two semicircles are cut out.

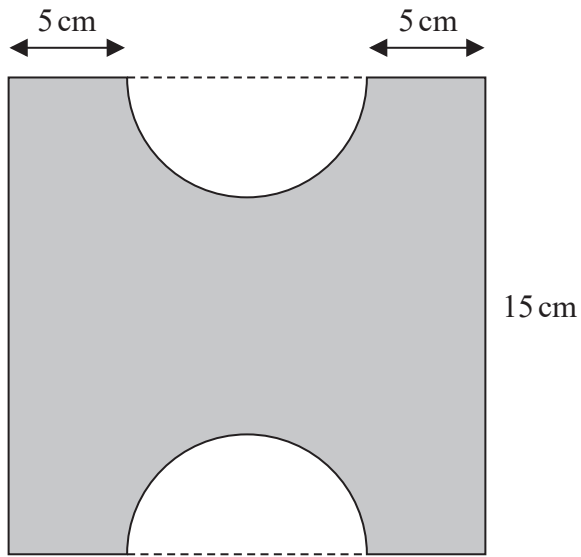

Diagram NOT accurately drawn

The square has a side of length 15 cm.

Calculate the area, in cm^2 to 3 significant figures, of the piece of card left when the semicircles are cut out.

..... cm^2

(Total for Question 14 is 4 marks)

DO NOT WRITE IN THIS AREA

DO NOT WRITE IN THIS AREA

DO NOT WRITE IN THIS AREA



15 Solve the simultaneous equations

$$\begin{aligned} 9x + 7y &= 3 \\ 5x - 4y &= 6.4 \end{aligned}$$

Show clear algebraic working.

$x =$

$y =$

(Total for Question 15 is 4 marks)

DO NOT WRITE IN THIS AREA

DO NOT WRITE IN THIS AREA

DO NOT WRITE IN THIS AREA



16

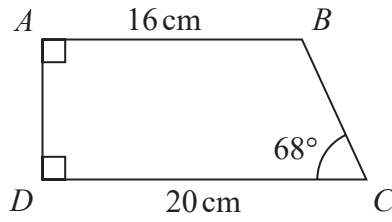

Diagram **NOT** accurately drawn

<https://britishstudy.com/>

DO NOT WRITE IN THIS AREA

DO NOT WRITE IN THIS AREA

DO NOT WRITE IN THIS AREA

The diagram shows trapezium $ABCD$ in which

$$AB = 16 \text{ cm} \quad DC = 20 \text{ cm} \quad \angle BCD = 68^\circ \quad \angle BAD = \angle CDA = 90^\circ$$

Calculate the area, in cm^2 to 3 significant figures, of trapezium $ABCD$

..... cm^2

(Total for Question 16 is 4 marks)



17 The Venn diagram shows the sets D , E and F where the numbers represent **numbers** of elements.

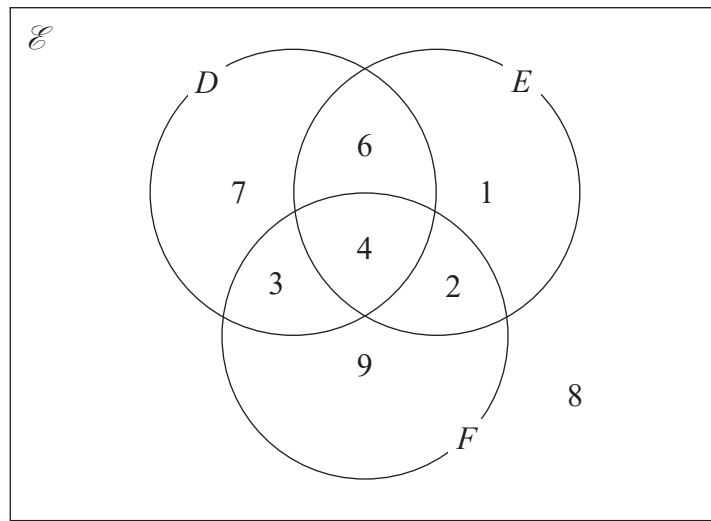

(a) Find $n(D \cup E)$

.....
(1)

(b) Find $n(D \cap E')$

.....
(1)

(c) Find $n(F')$

.....
(1)

(d) Find $n([D \cup F] \cap E')$

.....
(1)

(Total for Question 17 is 4 marks)

DO NOT WRITE IN THIS AREA

DO NOT WRITE IN THIS AREA

DO NOT WRITE IN THIS AREA



18 Make b the subject of $a = \sqrt{\frac{3b + 5}{b - d}}$

DO NOT WRITE IN THIS AREA

DO NOT WRITE IN THIS AREA

DO NOT WRITE IN THIS AREA

(Total for Question 18 is 4 marks)



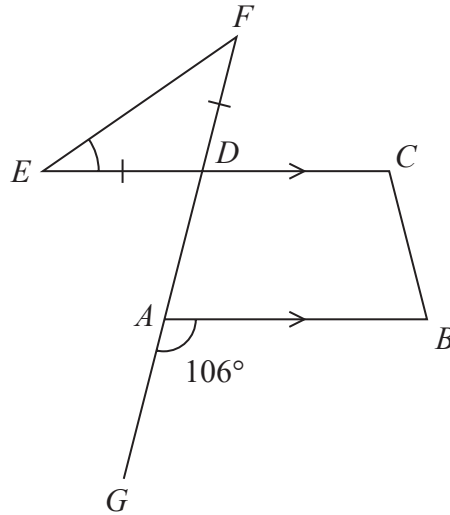

In the diagram, $ABCD$ is a trapezium and EDF is an isosceles triangle with $DE = DF$
 EDC and GAD are straight lines.

$\angle GAB = 106^\circ$

Calculate the size, in degrees, of $\angle DEF$
 Give reasons for each stage of your working.

$\angle DEF = \dots\dots\dots^\circ$

(Total for Question 19 is 5 marks)

DO NOT WRITE IN THIS AREA

DO NOT WRITE IN THIS AREA

DO NOT WRITE IN THIS AREA



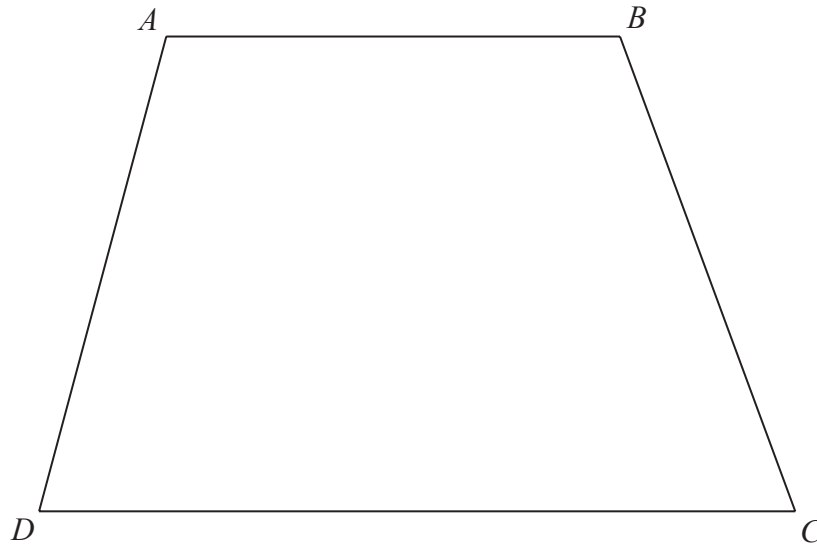

The diagram shows a quadrilateral $ABCD$

- (a) Construct the locus of all points inside the quadrilateral that are 5 cm from D (1)
- (b) Using ruler and compasses only and **showing all your construction lines**, construct the locus of all points inside the quadrilateral that are equidistant from AB and BC (2)
- (c) Construct the locus of all points inside the quadrilateral that are 3 cm from BC (1)

The region R consists of all the points inside the quadrilateral that are more than 5 cm from D , nearer to BC than to AB and more than 3 cm from BC

- (d) Show, by shading, the region R
Label the region R (1)

(Total for Question 20 is 5 marks)



21 $(x + 2)$ is a factor of $6x^3 + 31x^2 + kx + 30$

(a) Use the factor theorem to show that $k = 53$

(2)

(b) Factorise fully $6x^3 + 31x^2 + 53x + 30$

.....
(3)

(Total for Question 21 is 5 marks)

DO NOT WRITE IN THIS AREA

DO NOT WRITE IN THIS AREA

DO NOT WRITE IN THIS AREA



22

$$\mathbf{A} = \begin{pmatrix} 3 & 4 \\ 2 & -3 \end{pmatrix} \quad \mathbf{B} = \begin{pmatrix} -2 & 3 \\ 4 & -1 \end{pmatrix} \quad \mathbf{C} = \begin{pmatrix} 7 & x \\ 2 & 4 \end{pmatrix}$$

(a) Find $4\mathbf{A} - 2\mathbf{B}$

$$\begin{pmatrix} & \\ & \end{pmatrix} \quad (2)$$

Given the determinant of \mathbf{BC} is 20

(b) find the value of x

$$x = \dots\dots\dots (4)$$

(Total for Question 22 is 6 marks)

<https://britishstudentroom.com/>

DO NOT WRITE IN THIS AREA

DO NOT WRITE IN THIS AREA

DO NOT WRITE IN THIS AREA



23 (a) Simplify $7y^0$ where $y > 0$

.....
(1)

(b) Solve $\frac{2^2 \times 15^{2x} \times 3^{5x(x-3)} \times 3^{x+3} \times 4^{x-1}}{10^{2x}} = 81^3$

$x =$

(5)

(Total for Question 23 is 6 marks)

DO NOT WRITE IN THIS AREA

DO NOT WRITE IN THIS AREA

DO NOT WRITE IN THIS AREA



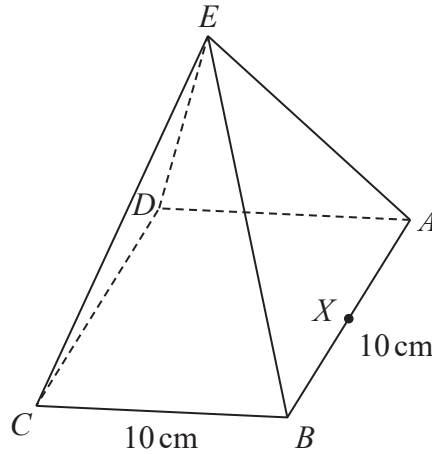

The diagram shows a solid right square-based pyramid $ABCDE$
 The volume of the pyramid is 1000 cm^3

The pyramid is standing with its square base, $ABCD$, on a horizontal table.
 The square base has side 10 cm.

X is the midpoint of the side AB

Calculate the size, in degrees to the nearest degree, of $\angle CEX$



DO NOT WRITE IN THIS AREA

DO NOT WRITE IN THIS AREA

DO NOT WRITE IN THIS AREA

o

(Total for Question 24 is 5 marks)



P 7 2 4 7 8 A 0 1 9 2 4

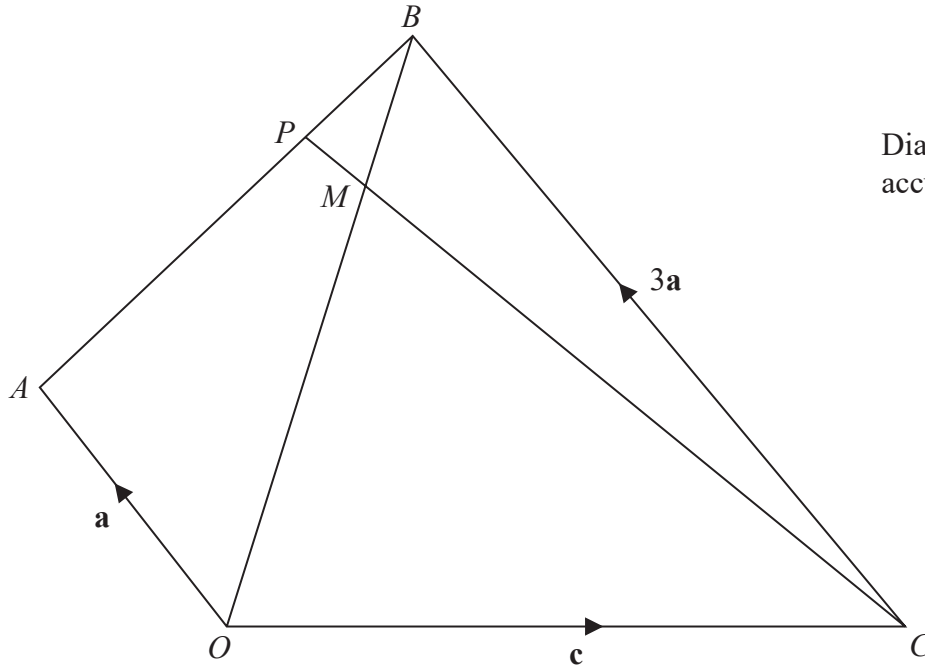

The diagram shows a quadrilateral $OABC$ in which

$$\vec{OA} = \mathbf{a} \quad \vec{OC} = \mathbf{c} \quad \vec{CB} = 3\mathbf{a}$$

The point M lies on OB such that $OM:MB = 7:3$
 The point P lies on AB such that CMP is a straight line.

(a) Find, in terms of \mathbf{a} and \mathbf{c} , simplifying your answer, the vector \vec{CM}

$$\vec{CM} = \dots\dots\dots (3)$$

DO NOT WRITE IN THIS AREA

DO NOT WRITE IN THIS AREA

DO NOT WRITE IN THIS AREA



(b) Using a vector method, and showing your working clearly, find $AP:PB$ in the form $x:y$ where x and y are integers.
Show your working clearly.

DO NOT WRITE IN THIS AREA

DO NOT WRITE IN THIS AREA

DO NOT WRITE IN THIS AREA

$AP:PB = \dots\dots\dots$
(4)

(Total for Question 25 is 7 marks)



26 Jenny has a shop.

One Monday, each of the 40 people who went in Jenny's shop were asked how long they were in the shop.

The table below shows information about the results.

Time (t minutes)	Frequency
$0 < t \leq 5$	10
$5 < t \leq 15$	7
$15 < t \leq 25$	5
$25 < t \leq 30$	6
$30 < t \leq 40$	12

- (a) Calculate an estimate for the mean length of time, in minutes, that these people were in the shop.

..... minutes
(4)



The incomplete table and the incomplete histogram give information about the number of kilometres each of the 40 people had travelled to get to the shop.

Distance (k kilometres)	Frequency
$0 < k \leq 10$	4
$10 < k \leq 15$	
$15 < k \leq 30$	
$30 < k \leq 60$	6

None of the people travelled more than 60 km.

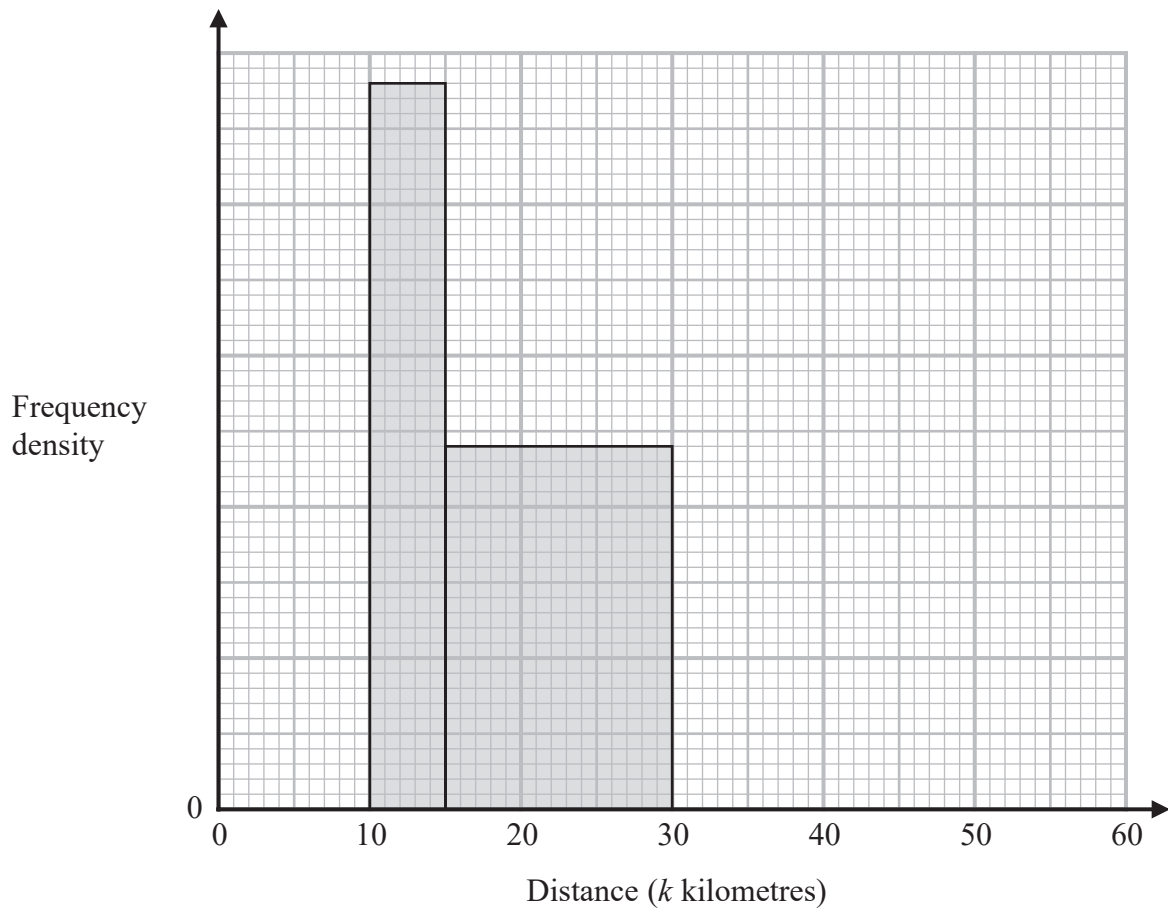

(b) Complete the histogram and the frequency table.

(4)

(Total for Question 26 is 8 marks)

TOTAL FOR PAPER IS 100 MARKS

DO NOT WRITE IN THIS AREA

DO NOT WRITE IN THIS AREA

DO NOT WRITE IN THIS AREA



BLANK PAGE

