

Please check the examination details below before entering your candidate information

Candidate surname

Other names

Centre Number

Candidate Number

--	--	--	--	--

--	--	--	--

# Pearson Edexcel International GCSE

Time 1 hour 30 minutes

Paper  
reference

**4MB1/01**

## Mathematics B PAPER 1



**You must have:** Ruler graduated in centimetres and millimetres, protractor, pair of compasses, pen, HB pencil, eraser, calculator. Tracing paper may be used.

Total Marks

### Instructions

- Use **black** ink or ball-point pen.
- **Fill in the boxes** at the top of this page with your name, centre number and candidate number.
- Answer **all** questions.
- Answer the questions in the spaces provided – *there may be more space than you need.*
- **Calculators may be used.**

### Information

- The total mark for this paper is 100.
- The marks for **each** question are shown in brackets – *use this as a guide as to how much time to spend on each question.*

### Advice

- Read each question carefully before you start to answer it.
- Check your answers if you have time at the end.
- Without sufficient working, correct answers may be awarded no marks.

Turn over ►

P68816A

©2022 Pearson Education Ltd.

1/1/1/



Pearson

**Answer all TWENTY SEVEN questions.**

**Write your answers in the spaces provided.**

**You must write down all the stages in your working.**

- 1** Find the Lowest Common Multiple (LCM) of 180 and 198  
Show your working clearly.

.....  
**(Total for Question 1 is 2 marks)**

- 2** Factorise fully  $6p^3q^5r - 15pq^3$

.....  
**(Total for Question 2 is 2 marks)**

DO NOT WRITE IN THIS AREA

DO NOT WRITE IN THIS AREA

DO NOT WRITE IN THIS AREA



DO NOT WRITE IN THIS AREA

DO NOT WRITE IN THIS AREA

DO NOT WRITE IN THIS AREA

3 Find the value of  $\frac{11 - 2a^2}{b}$  when  $a = -2$  and  $b = -3$

(Total for Question 3 is 2 marks)

4

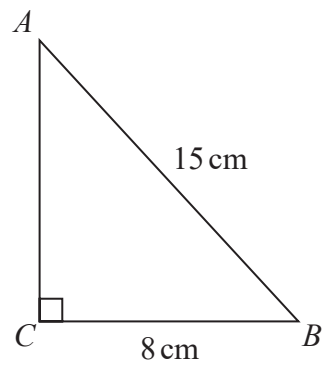

Diagram NOT accurately drawn

The diagram shows the right-angled triangle in which

$$AB = 15 \text{ cm} \quad BC = 8 \text{ cm} \quad \angle ACB = 90^\circ$$

Calculate the size, in degrees to 3 significant figures, of  $\angle ABC$

$$\angle ABC = \dots\dots\dots^\circ$$

(Total for Question 4 is 2 marks)



5

$$A = \begin{pmatrix} 5 & -4 \\ 2 & -2 \end{pmatrix} \quad B = \begin{pmatrix} 3 & -2 \\ -2 & 5 \end{pmatrix}$$

Calculate  $4A - 3B$

$$\left( \begin{array}{cc} & \\ & \end{array} \right)$$

(Total for Question 5 is 2 marks)

6 The  $n$ th term of a sequence is given by  $3n - 5$

(a) Write down the first two terms of this sequence.

....., .....

(1)

The  $m$ th term of this sequence is 103

(b) Find the value of  $m$

$m =$  .....

(2)

(Total for Question 6 is 3 marks)



DO NOT WRITE IN THIS AREA

DO NOT WRITE IN THIS AREA

DO NOT WRITE IN THIS AREA

7 A straight line **L** passes through the points with coordinates (4, 8) and (0, -6)

Find an equation of **L**

Give your answer in the form  $y = mx + c$

(Total for Question 7 is 3 marks)

8

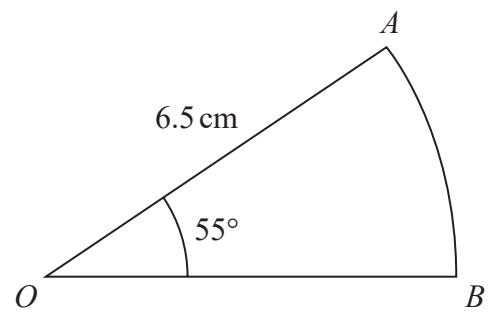

Diagram NOT accurately drawn

*OAB* is a sector of a circle, centre *O* and radius 6.5 cm

$$\angle AOB = 55^\circ$$

Calculate the perimeter, in cm to 3 significant figures, of the sector *OAB*

..... cm

(Total for Question 8 is 3 marks)



9 Simplify  $\frac{(25x^4y^2)^{\frac{3}{2}}}{25x^3}$

(Total for Question 9 is 3 marks)

10

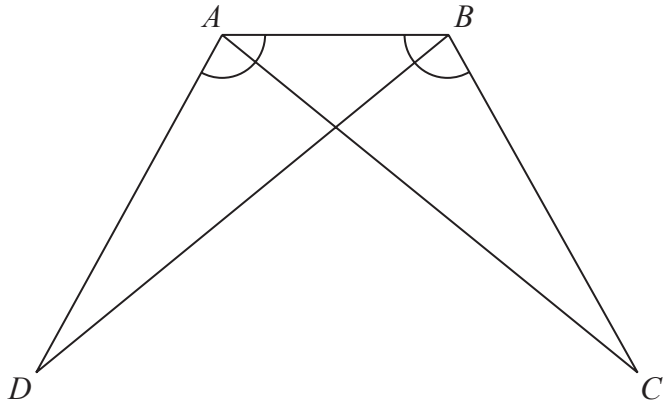

Diagram NOT accurately drawn

In the diagram, triangles  $ABC$  and  $ABD$  are such that

$AD = BC$  and  $\angle BAD = \angle ABC$

Prove that  $AC = BD$

(Total for Question 10 is 3 marks)



DO NOT WRITE IN THIS AREA

DO NOT WRITE IN THIS AREA

DO NOT WRITE IN THIS AREA

11

<https://britishstudent.com/qa/webapp/>  
Diagram NOT accurately drawn

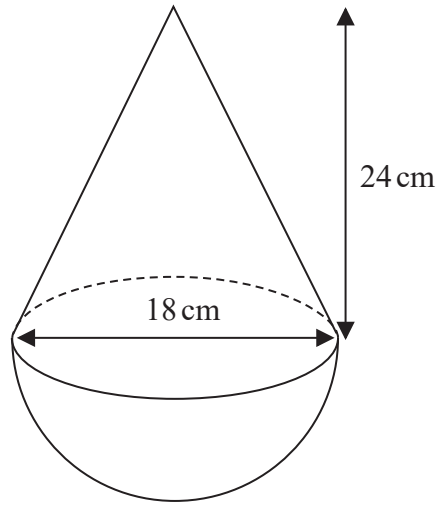

A solid is made by joining a hemisphere, of diameter 18 cm, to a right circular cone whose base has a diameter of 18 cm. The height of the cone is 24 cm.

The plane face of the cone coincides with the plane face of the hemisphere.

Calculate the volume, in  $\text{cm}^3$ , of the solid.  
Give your answer in terms of  $\pi$

.....  $\text{cm}^3$

(Total for Question 11 is 3 marks)

DO NOT WRITE IN THIS AREA

DO NOT WRITE IN THIS AREA

DO NOT WRITE IN THIS AREA



12 Given that  $y = \frac{x^2 + x + 1}{x}$  where  $x \neq 0$

find  $\frac{dy}{dx}$

$$\frac{dy}{dx} = \dots\dots\dots$$

(Total for Question 12 is 3 marks)

13 Without using a calculator and showing your working clearly, express

$$\sqrt{432} - \sqrt{147}$$

in the form  $\sqrt{n}$  where  $n$  is an integer.

.....  
(Total for Question 13 is 3 marks)

DO NOT WRITE IN THIS AREA

DO NOT WRITE IN THIS AREA

DO NOT WRITE IN THIS AREA





DO NOT WRITE IN THIS AREA

14 **A** and **B** are two similar solids.

The volume of **A** is  $500 \text{ cm}^3$

The volume of **B** is  $32 \text{ cm}^3$

The total surface area of **A** is  $250 \text{ cm}^2$

Calculate the total surface area, in  $\text{cm}^2$ , of **B**.

.....  $\text{cm}^2$

(Total for Question 14 is 3 marks)



15 The table gives information about the weights, in grams, of 40 adult mice.

Weight ( $w$ grams)	Frequency
$17 \leq w < 19$	8
$19 \leq w < 21$	3
$21 \leq w < 22$	15
$22 \leq w < 23$	8
$23 \leq w < 25$	6

DO NOT WRITE IN THIS AREA

DO NOT WRITE IN THIS AREA

DO NOT WRITE IN THIS AREA

(a) Calculate an estimate for the mean weight, in grams to 3 significant figures, of these adult mice.

..... grams  
(3)

One of these adult mice is selected at random.

(b) Find the probability that this mouse weighs less than 22 grams.

.....  
(1)

(Total for Question 15 is 4 marks)



DO NOT WRITE IN THIS AREA

DO NOT WRITE IN THIS AREA

DO NOT WRITE IN THIS AREA

16 Andrew borrowed some money from Sarah.

He borrowed \$21 250 on 1st January 2018

On 31st December each year, starting on 31st December 2018, Sarah charged Andrew interest of 4% on the amount of money that he owed her. This interest was added to the amount of money that Andrew owed Sarah.

On 1st January each year, starting on 1st January 2019, Andrew repaid \$4000 to Sarah.

(a) Show that before Andrew had repaid \$4000 to Sarah on 1st January 2019, he owed Sarah \$22 100

(1)

After Andrew had repaid \$4000 to Sarah on 1st January 2020,

(b) calculate how much money Andrew now owed Sarah.

\$.....

(3)

(Total for Question 16 is 4 marks)



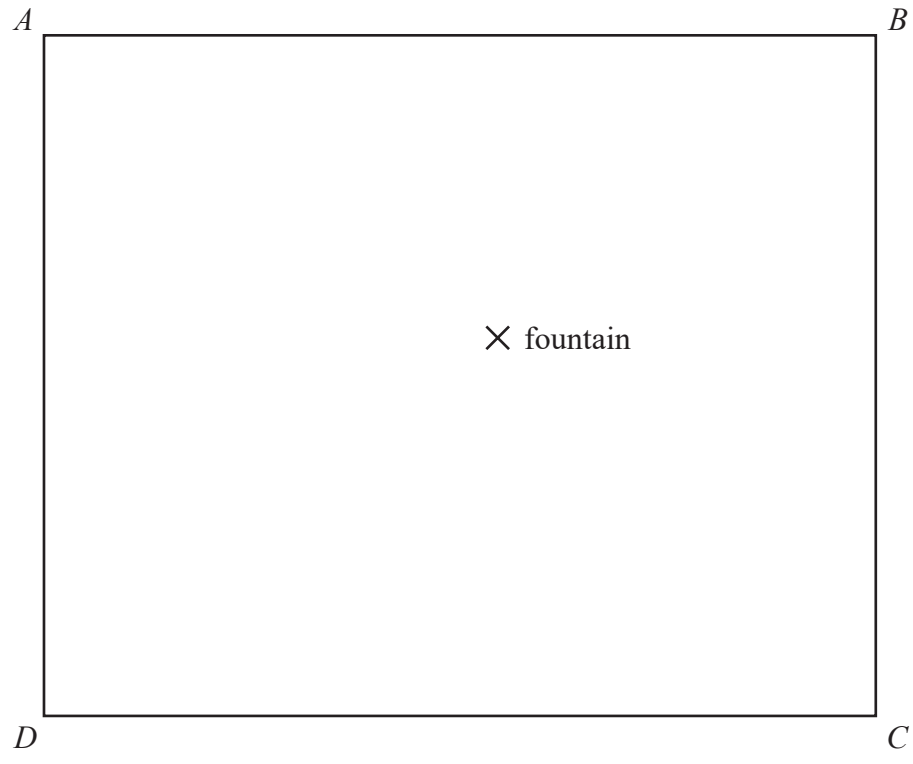

Scale: 1 cm represents 1 m

DO NOT WRITE IN THIS AREA

DO NOT WRITE IN THIS AREA

DO NOT WRITE IN THIS AREA

The diagram shows a scale drawing of a garden in the shape of the rectangle  $ABCD$ . The position of a fountain in the garden is marked by a cross.

Tarik is going to plant a tree in the garden.

The tree must be

- less than 2 metres from  $AB$ ,
- greater than 3 metres from the fountain,
- closer to  $AB$  than to  $AC$ .

Using ruler and compasses only and **showing all your construction lines**, construct and show by shading the region in which Tarik can plant the tree. Label the region **R**.

(Total for Question 17 is 4 marks)



18

<https://britishstudent.com/qa/webapp/>  
Diagram NOT accurately drawn

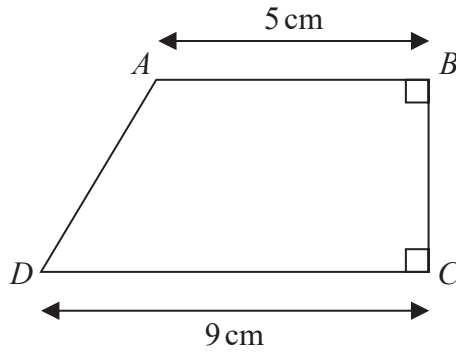

The diagram shows a trapezium  $ABCD$ .

$$\angle ABC = \angle BCD = 90^\circ$$

$$AB = 5 \text{ cm}$$

$$DC = 9 \text{ cm}$$

The area of the trapezium  $ABCD$  is  $29.4 \text{ cm}^2$

Calculate the length, in cm, of  $AD$ .

..... cm

(Total for Question 18 is 4 marks)

DO NOT WRITE IN THIS AREA



19 The sum of the interior angles of a regular polygon is  $8280^\circ$

Calculate the size, in degrees, of each exterior angle of the regular polygon.

DO NOT WRITE IN THIS AREA

DO NOT WRITE IN THIS AREA

DO NOT WRITE IN THIS AREA

o

(Total for Question 19 is 4 marks)



20 The numbers  $p$  and  $q$  are positive such that  $p$  is inversely proportional to  $\sqrt{q}$

$p = 420$  when  $q = 9$

Calculate the value of  $q$  when  $p = 28$

DO NOT WRITE IN THIS AREA

DO NOT WRITE IN THIS AREA

DO NOT WRITE IN THIS AREA

$q = \dots\dots\dots$

(Total for Question 20 is 4 marks)







22 Express  $\frac{8 - 7x}{6x^2 + 7x - 10} \div \left( \frac{3}{5x - 1} - \frac{2}{x + 2} \right)$  as a single fraction in its simplest form.

Show clear algebraic working.

DO NOT WRITE IN THIS AREA

DO NOT WRITE IN THIS AREA

DO NOT WRITE IN THIS AREA

.....  
(Total for Question 22 is 4 marks)



23 A bag contains 20 balls. Each ball has either the number 5 on it or the number 6 on it

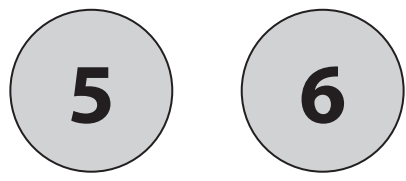

There are 12 balls with the number 5  
There are 8 balls with the number 6

Ben takes at random 2 balls from the bag.

(a) Complete the probability tree diagram.

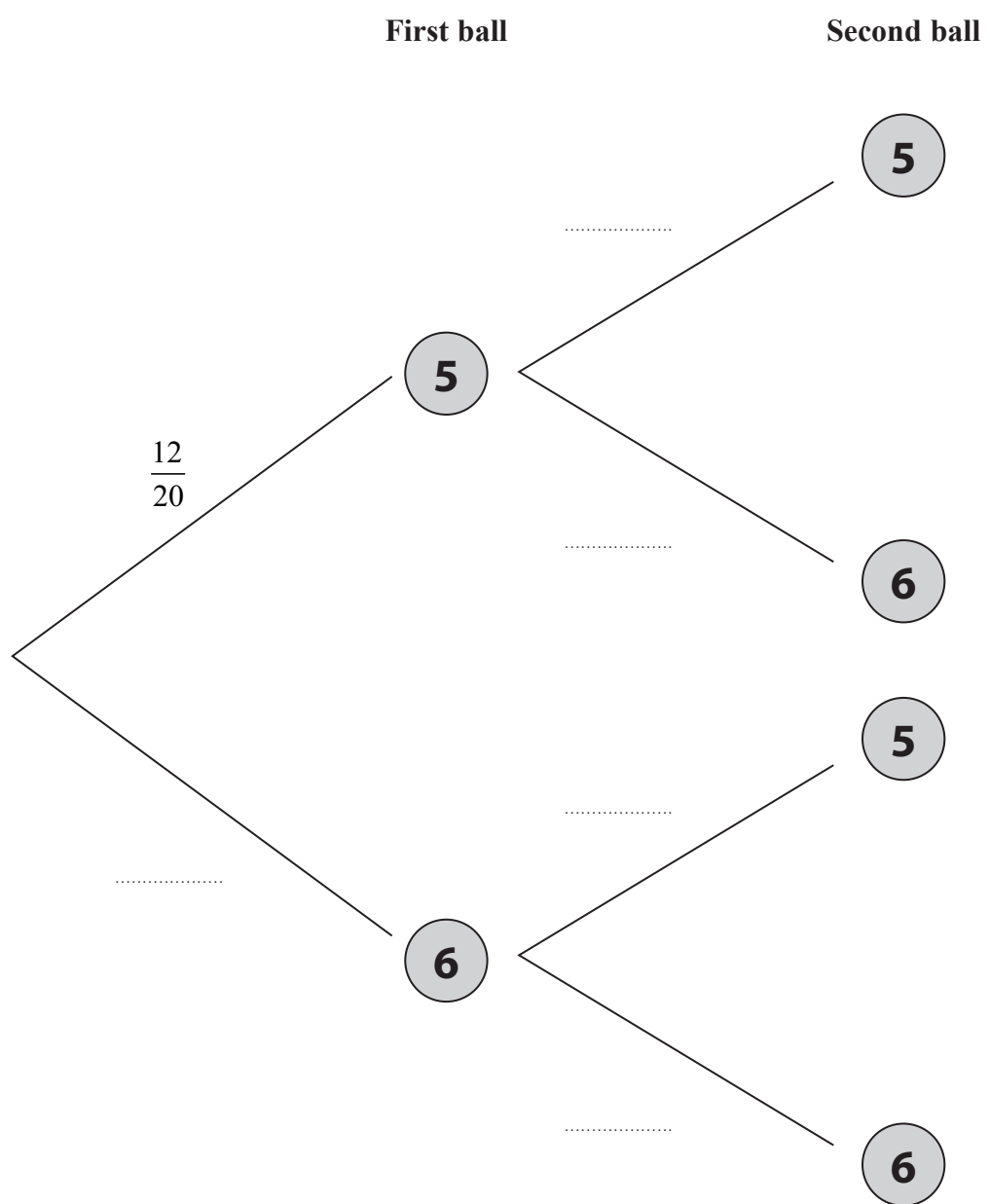

(3)

DO NOT WRITE IN THIS AREA

DO NOT WRITE IN THIS AREA

DO NOT WRITE IN THIS AREA



- (b) Calculate the probability that the sum of the numbers on the two balls is greater than 10  
Give your answer as a fraction.

<https://brainiacstudentroom-b430a.web.app/>

DO NOT WRITE IN THIS AREA

DO NOT WRITE IN THIS AREA

DO NOT WRITE IN THIS AREA

.....  
(3)

(Total for Question 23 is 6 marks)



P 6 8 8 1 6 A 0 1 9 2 4

24 The two digit number  $M$  has tens digit  $p$  and units digit  $q$   
The two digit number  $N$  has tens digit  $q$  and units digit  $p$

Given that  $N - M = 9$  and that  $p + q = 13$

find the value of  $M$

Show clear algebraic working.

DO NOT WRITE IN THIS AREA

DO NOT WRITE IN THIS AREA

DO NOT WRITE IN THIS AREA

$M = \dots\dots\dots$

(Total for Question 24 is 5 marks)



DO NOT WRITE IN THIS AREA

DO NOT WRITE IN THIS AREA

DO NOT WRITE IN THIS AREA

25 By writing  $8x^2 - 56x + 17$  in the form  $p(x + q)^2 + r$  find the exact solutions of the equation

$$8x^2 - 56x + 17 = 0$$

Give your answer in the form  $\frac{a \pm b\sqrt{2}}{c}$  where  $a, b$  and  $c$  are integers.

Show your working clearly.

$x = \dots\dots\dots$

(Total for Question 25 is 6 marks)



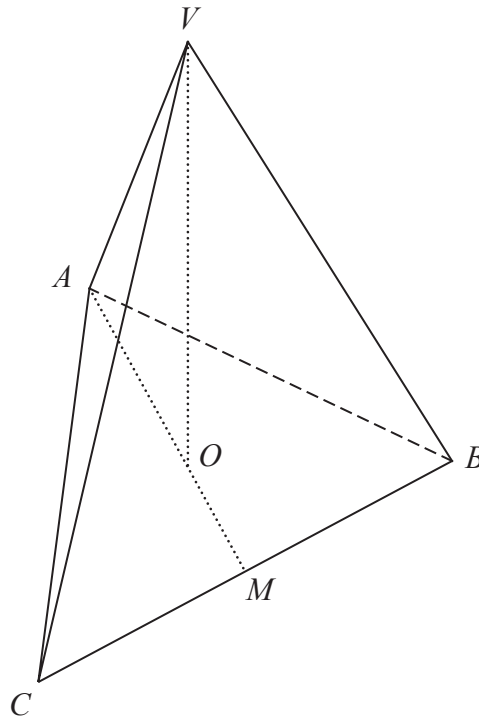

The diagram shows a solid pyramid with a triangular base  $ABC$ , which is an equilateral triangle of side  $8\sqrt{3}$  cm.

The base of the pyramid is on a horizontal surface and the vertex  $V$  of the pyramid is vertically above the point  $O$  of the base.

The edges  $AV$ ,  $BV$  and  $CV$  of the pyramid are the same length and  $O$  lies on  $AM$ , where  $M$  is the midpoint of  $CB$  and  $AO:OM = 2:1$

Given that the total surface area of the pyramid is  $150\sqrt{3}$  cm<sup>2</sup>,

find the length, in cm, of  $VO$ .



DO NOT WRITE IN THIS AREA

DO NOT WRITE IN THIS AREA

DO NOT WRITE IN THIS AREA

..... cm

**(Total for Question 26 is 7 marks)**

**Turn over for Question 27**



<https://britishspeedcentre.com-b430a.web.app/>

27 Egan cycled 168 km at an average speed of  $x$  km/h,  
Rohan cycled the 168 km at an average speed that was 2 km/h less than Egan's average speed.  
Given that it took Rohan 12 minutes longer than Egan to cycle the 168 km,  
calculate the value of  $x$

DO NOT WRITE IN THIS AREA

DO NOT WRITE IN THIS AREA

DO NOT WRITE IN THIS AREA

$x = \dots\dots\dots$

(Total for Question 27 is 7 marks)

**TOTAL FOR PAPER IS 100 MARKS**

