

Please check the examination details below before entering your candidate information

Candidate surname

Other names

Centre Number

Candidate Number

--	--	--	--	--

--	--	--	--

Pearson Edexcel International GCSE

Time 2 hours

Paper
reference

4MA1/2HR

Mathematics A

PAPER 2HR

Higher Tier



You must have: Ruler graduated in centimetres and millimetres, protractor, pair of compasses, pen, HB pencil, eraser, calculator. Tracing paper may be used.

Total Marks

Instructions

- Use **black** ink or ball-point pen.
- **Fill in the boxes** at the top of this page with your name, centre number and candidate number.
- Answer **all** questions.
- Without sufficient working, correct answers may be awarded no marks.
- Answer the questions in the spaces provided
– *there may be more space than you need.*
- **Calculators may be used.**
- You must **NOT** write anything on the formulae page.
Anything you write on the formulae page will gain NO credit.

Information

- The total mark for this paper is 100.
- The marks for **each** question are shown in brackets
– *use this as a guide as to how much time to spend on each question.*

Advice

- Read each question carefully before you start to answer it.
- Check your answers if you have time at the end.

Turn over ►

P68729A

©2022 Pearson Education Ltd.

L:1/1/1/



P 6 8 7 2 9 A 0 1 3 2



Pearson

International GCSE Mathematics
Formulae sheet – Higher Tier

<https://britishstudentroom-b430a.web.app/>

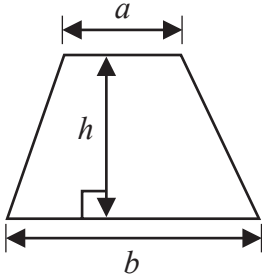
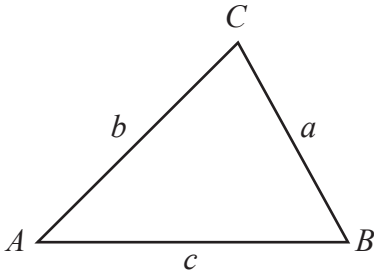
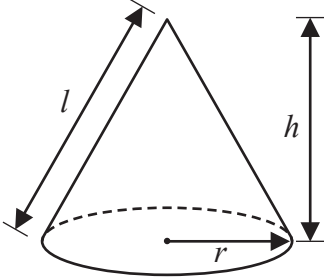
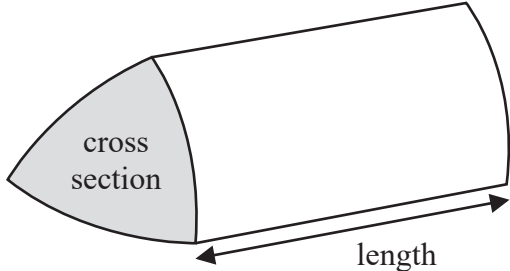
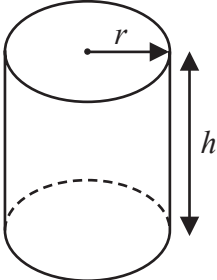
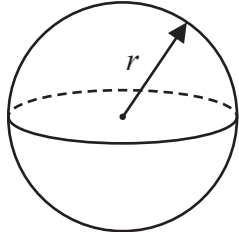
<p>Arithmetic series</p> <p>Sum to n terms, $S_n = \frac{n}{2} [2a + (n - 1)d]$</p>	<p>Area of trapezium = $\frac{1}{2}(a + b)h$</p>
<p>The quadratic equation</p> <p>The solutions of $ax^2 + bx + c = 0$ where $a \neq 0$ are given by:</p> $x = \frac{-b \pm \sqrt{b^2 - 4ac}}{2a}$	
<p>Trigonometry</p> 	<p>In any triangle ABC</p> <p>Sine Rule $\frac{a}{\sin A} = \frac{b}{\sin B} = \frac{c}{\sin C}$</p> <p>Cosine Rule $a^2 = b^2 + c^2 - 2bc \cos A$</p> <p>Area of triangle = $\frac{1}{2} ab \sin C$</p>
<p>Volume of cone = $\frac{1}{3} \pi r^2 h$</p> <p>Curved surface area of cone = $\pi r l$</p> 	<p>Volume of prism = area of cross section \times length</p> 
<p>Volume of cylinder = $\pi r^2 h$</p> <p>Curved surface area of cylinder = $2\pi r h$</p> 	<p>Volume of sphere = $\frac{4}{3} \pi r^3$</p> <p>Surface area of sphere = $4\pi r^2$</p> 

DO NOT WRITE IN THIS AREA

DO NOT WRITE IN THIS AREA

DO NOT WRITE IN THIS AREA



Answer ALL TWENTY THREE questions.

Write your answers in the spaces provided.

You must write down all the stages in your working.

- 1** A tin contains tea bags with a choice of four different flavours of tea. The four flavours of tea are Assam or Darjeeling or Nilgiri or Rize.

Sara takes at random a tea bag from the tin.

The table shows each of the probabilities that the flavour of the tea Sara takes is Assam or Darjeeling or Rize.

Flavour of tea	Assam	Darjeeling	Nilgiri	Rize
Probability	0.38	0.24		0.16

- (a) Work out the probability that the flavour of the tea Sara takes is Nilgiri.

.....
(2)

- (b) Work out the probability that the flavour of the tea Sara takes is either Darjeeling or Rize.

.....
(2)

(Total for Question 1 is 4 marks)

DO NOT WRITE IN THIS AREA

DO NOT WRITE IN THIS AREA

DO NOT WRITE IN THIS AREA



2 Mary saves for a holiday each year.

In 2020 she saved a total of \$720

In 2021, each month she saved \$78

The total amount Mary saved in 2021 was $P\%$ more than the total she saved in 2020

(a) Work out the value of P

DO NOT WRITE IN THIS AREA

DO NOT WRITE IN THIS AREA

DO NOT WRITE IN THIS AREA

.....
(4)



Roberto is going to go on holiday.

He has two coupons that will save him money on his holiday.

Coupon A
18% off the cost of the accommodation

Coupon B
12.5% off the total cost of the accommodation **and** the flights

For Roberto's holiday
the cost of the accommodation is \$1600
the cost of the flights is \$800

Roberto can only use one of the coupons.
He wants to save as much money as he can.

- (b) Which of the two coupons, **A** or **B**, should he use?
Show your working clearly.

(3)

(Total for Question 2 is 7 marks)

DO NOT WRITE IN THIS AREA

DO NOT WRITE IN THIS AREA

DO NOT WRITE IN THIS AREA



3 (a) Solve $4y + 5 > 12$

.....
(2)

(b) Solve $6x - 5 = \frac{4x - 7}{2}$

Show clear algebraic working.

$x =$
(3)

(Total for Question 3 is 5 marks)

DO NOT WRITE IN THIS AREA

DO NOT WRITE IN THIS AREA

DO NOT WRITE IN THIS AREA



4 The diagram shows a regular octagon $ABCDEFGH$ and a regular pentagon $ABIJK$

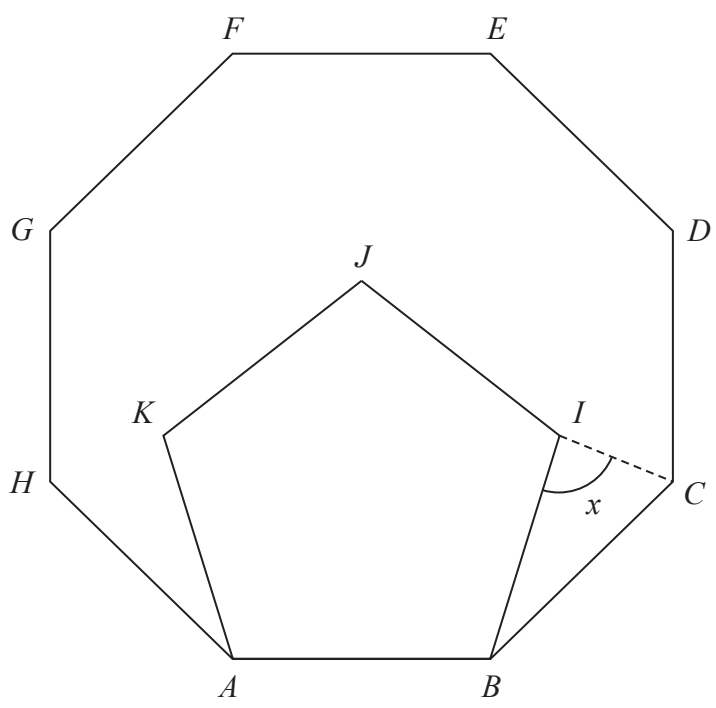

Diagram NOT accurately drawn

Work out the size of the angle x

(Total for Question 4 is 4 marks)

DO NOT WRITE IN THIS AREA

DO NOT WRITE IN THIS AREA

DO NOT WRITE IN THIS AREA



5 Shane invests 7200 dollars for 3 years in a savings account.
He gets 2.5% per year compound interest.

How much money will Shane have in his savings account at the end of 3 years?
Give your answer to the nearest dollar.

..... dollars

(Total for Question 5 is 3 marks)

DO NOT WRITE IN THIS AREA

DO NOT WRITE IN THIS AREA

DO NOT WRITE IN THIS AREA



DO NOT WRITE IN THIS AREA

DO NOT WRITE IN THIS AREA

DO NOT WRITE IN THIS AREA

6 (a) Write down the value of x^0

.....
(1)

Given that $2^{-3} \times 2^9 = 2^n$

(b) find the value of n

$n =$
(1)

Given that $\frac{7^{206} \times 7^m}{7^{214}} = 7^{-3}$

(c) find the value of m

$m =$
(2)

(Total for Question 6 is 4 marks)



7 (a) Write down an equation of the straight line with gradient -3 and which passes through the point with coordinates $(0, 5)$

.....
(2)

(b) Show, by shading on the grid, the region defined by **all three** of the inequalities

$x \leq 6$ $y \geq 2$ $y \leq x + 1$

Label the region **R**

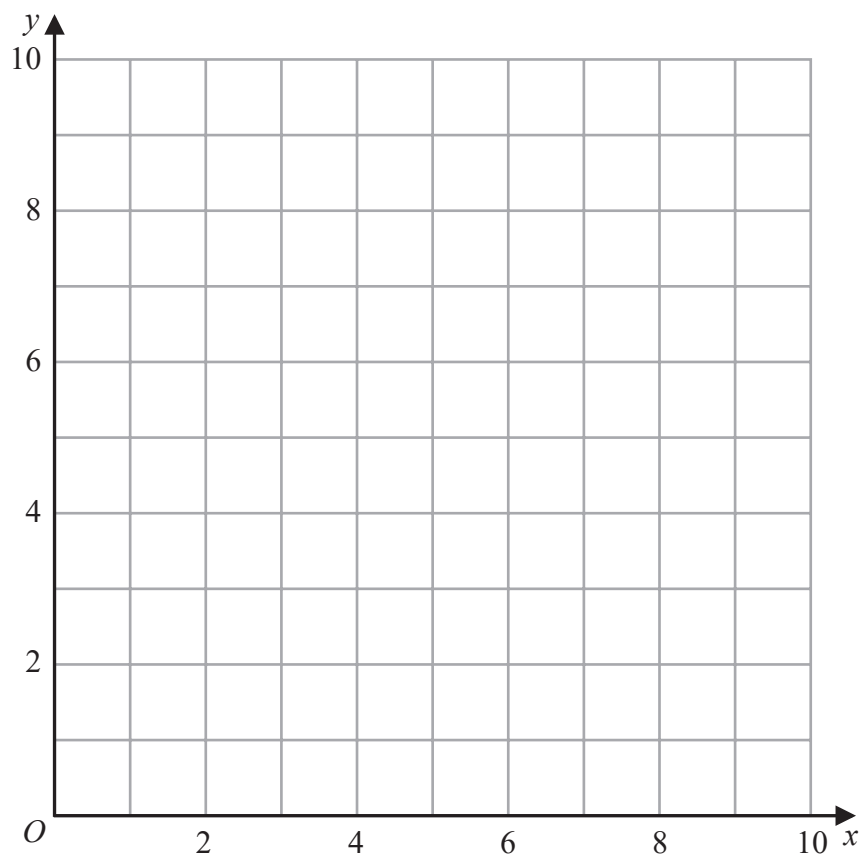

(3)

(Total for Question 7 is 5 marks)



DO NOT WRITE IN THIS AREA

8 A scientist is investigating the weight of 50 tigers.

Here is some information about these tigers.

	Type of tiger	
	Siberian	Bengal
Number of tigers	22	28
Mean weight of tigers (kg)	260	

The mean weight of all 50 tigers is 218 kg

Work out the mean weight of the Bengal tigers.

..... kg

(Total for Question 8 is 3 marks)



9 In the diagram, ABC is a right-angled triangle and DEF is a semicircular arc.

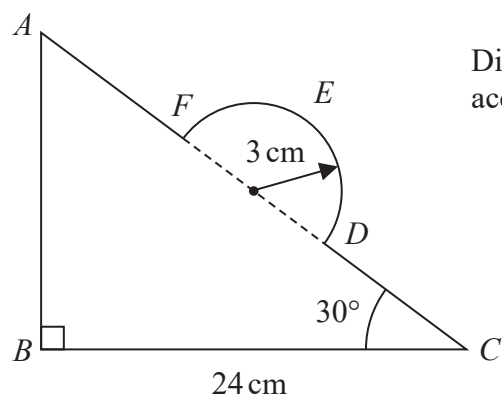

Diagram NOT accurately drawn

DO NOT WRITE IN THIS AREA

DO NOT WRITE IN THIS AREA

DO NOT WRITE IN THIS AREA

In triangle ABC

$BC = 24 \text{ cm}$ angle $ABC = 90^\circ$ angle $BCA = 30^\circ$

The points D and F lie on AC so that DF is the diameter of the semicircular arc DEF
The radius of the semicircular arc is 3 cm .

Work out the length of $AFEDC$
Give your answer correct to 2 significant figures.



DO NOT WRITE IN THIS AREA

DO NOT WRITE IN THIS AREA

DO NOT WRITE IN THIS AREA

..... cm

(Total for Question 9 is 5 marks)



10 The table gives information about the population and the total amount of money, in dollars, spent on healthcare for two countries in 2016

Country	Total population	Total spent on healthcare (\$)
Austria	8.7×10^6	4.2×10^{10}
Luxembourg	6.3×10^5	3.7×10^9

Work out how much more was spent **per person** on healthcare in Luxembourg than in Austria.
Give your answer correct to the nearest whole number.

..... dollars

(Total for Question 10 is 3 marks)

DO NOT WRITE IN THIS AREA
DO NOT WRITE IN THIS AREA
DO NOT WRITE IN THIS AREA



DO NOT WRITE IN THIS AREA

DO NOT WRITE IN THIS AREA

DO NOT WRITE IN THIS AREA

11 (a) Complete the table of values for $y = \frac{6}{x}$

x	0.5	1	2	3	4	5	6
y		6		2			1

(2)

(b) On the grid, draw the graph of $y = \frac{6}{x}$ for $0.5 \leq x \leq 6$

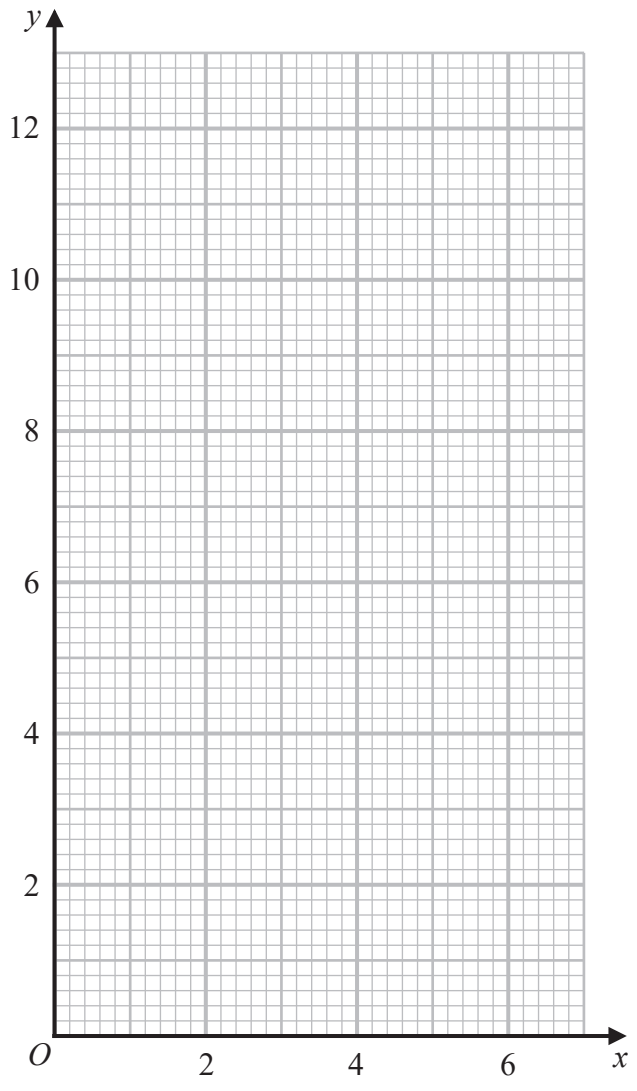

(2)

(Total for Question 11 is 4 marks)



12 The diagram shows two vertical phone masts, AB and CD , on horizontal ground.

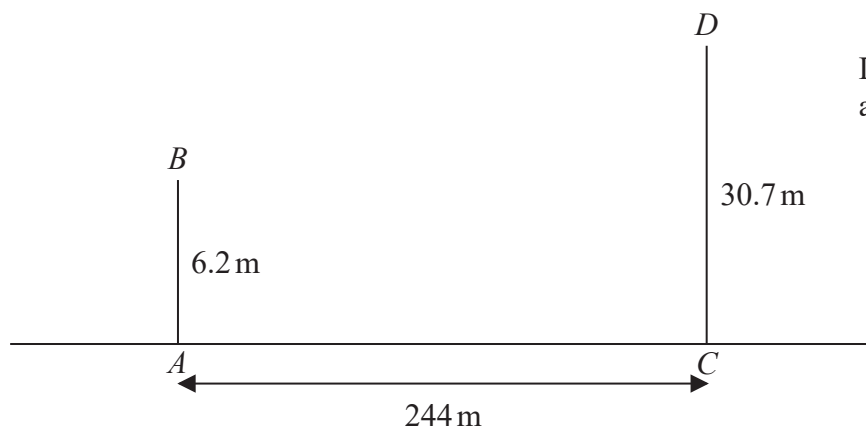

Diagram NOT accurately drawn

$$AB = 6.2\text{ m} \quad AC = 244\text{ m} \quad CD = 30.7\text{ m}$$

Work out the size of the angle of depression of B from D
Give your answer correct to one decimal place.

DO NOT WRITE IN THIS AREA

DO NOT WRITE IN THIS AREA

DO NOT WRITE IN THIS AREA

(Total for Question 12 is 3 marks)



DO NOT WRITE IN THIS AREA

DO NOT WRITE IN THIS AREA

DO NOT WRITE IN THIS AREA

13 $a = \sqrt{8} + 4$

$b = \sqrt{8} - 4$

$(a - b)(a + b)$ can be written in the form $y\sqrt{4y}$

Find the value of y
Show your working clearly.

$y = \dots\dots\dots$

(Total for Question 13 is 3 marks)



14 A group of 60 students each sat an algebra test and a geometry test.
Each test was marked out of 110

The cumulative frequency graph gives information about the marks gained by the 60 students in the algebra test.

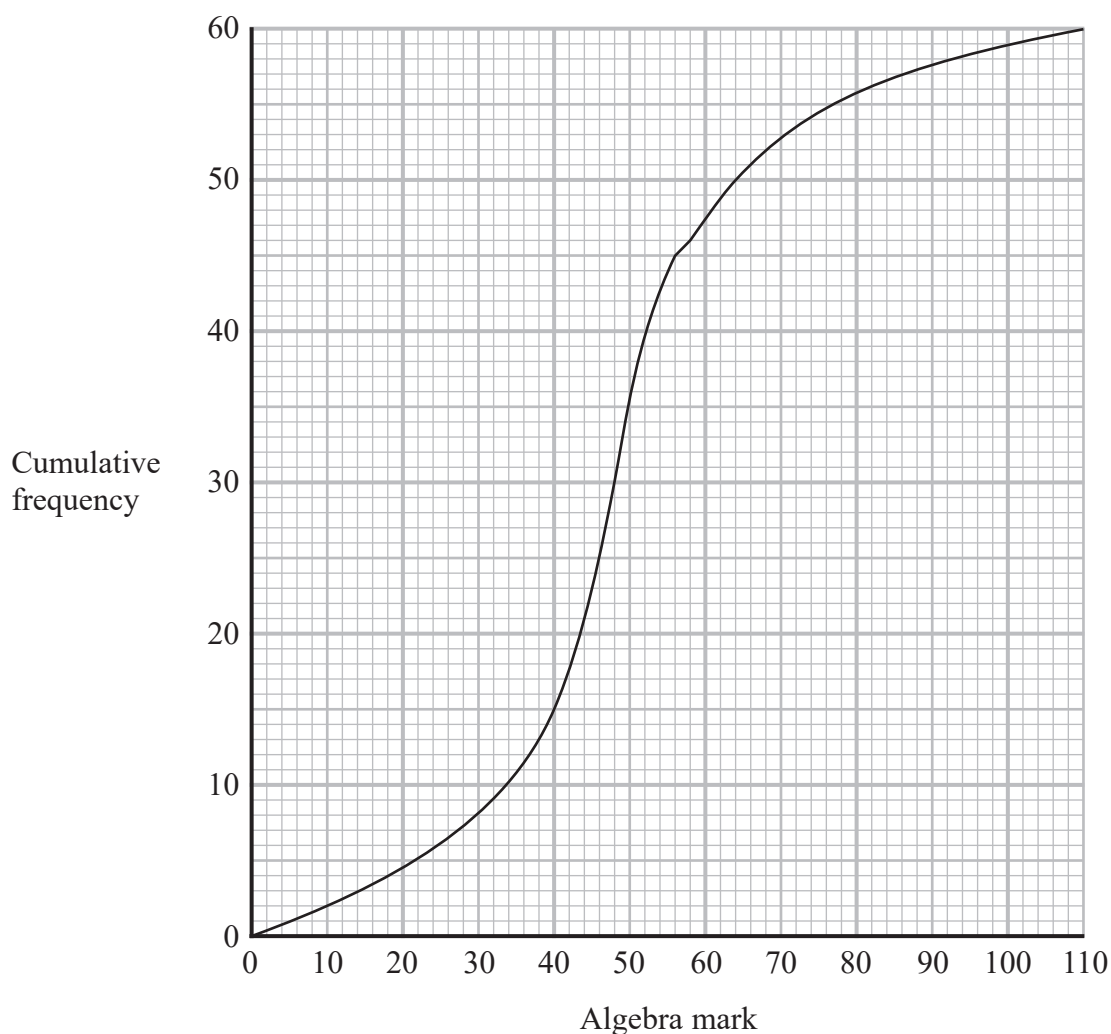

(a) Use the graph to find an estimate for the median mark in the algebra test.

.....
(1)

(b) Use the graph to find an estimate for the number of students who gained 58 marks or less in the algebra test.

.....
(1)

DO NOT WRITE IN THIS AREA

DO NOT WRITE IN THIS AREA

DO NOT WRITE IN THIS AREA



DO NOT WRITE IN THIS AREA

DO NOT WRITE IN THIS AREA

DO NOT WRITE IN THIS AREA

(c) Use the graph to find an estimate for the interquartile range of the marks gained in the algebra test.

.....
(2)

The interquartile range of the marks gained in the geometry test is 9

Luis says

“The students’ marks are more spread out in the algebra test than in the geometry test.”

(d) Is Luis correct?
Give a reason for your answer.

.....
.....
(1)

To be awarded a grade A in the algebra test, a student had to gain a mark greater than 64

Two students are to be selected at random from the 60 students in the group.

(e) Use the graph to find an estimate for the probability that both of these students were awarded a grade A in the algebra test.

.....
(3)

(Total for Question 14 is 8 marks)



P 6 8 7 2 9 A 0 1 9 3 2

15 Make t the subject of $n^2 = \frac{4d+t^3}{t^3}$

<https://britishstudentroom-b430a.web.app/>

DO NOT WRITE IN THIS AREA

DO NOT WRITE IN THIS AREA

DO NOT WRITE IN THIS AREA

.....
(Total for Question 15 is 4 marks)



16 The diagram shows quadrilateral $ABCD$

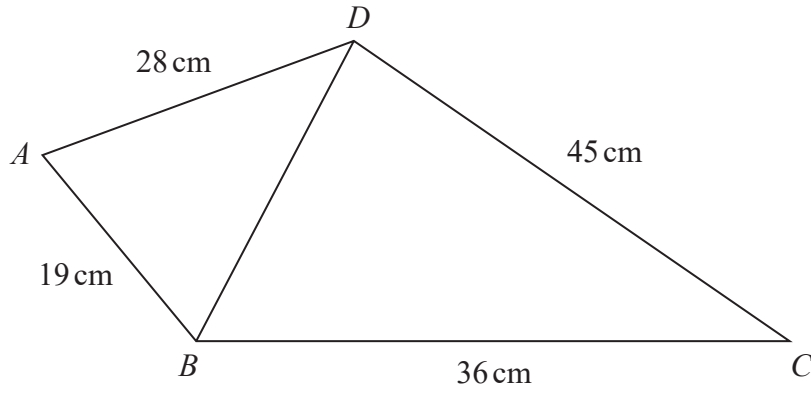

Diagram **NOT** accurately drawn

The angle BCD is acute.

Given that the area of triangle $BCD = 405$ cm²

work out the size of angle ABD

Give your answer correct to one decimal place.

DO NOT WRITE IN THIS AREA

DO NOT WRITE IN THIS AREA

DO NOT WRITE IN THIS AREA

(Total for Question 16 is 5 marks)

o



17 Part of the curve with equation $y = f(x)$ is shown on the grid.

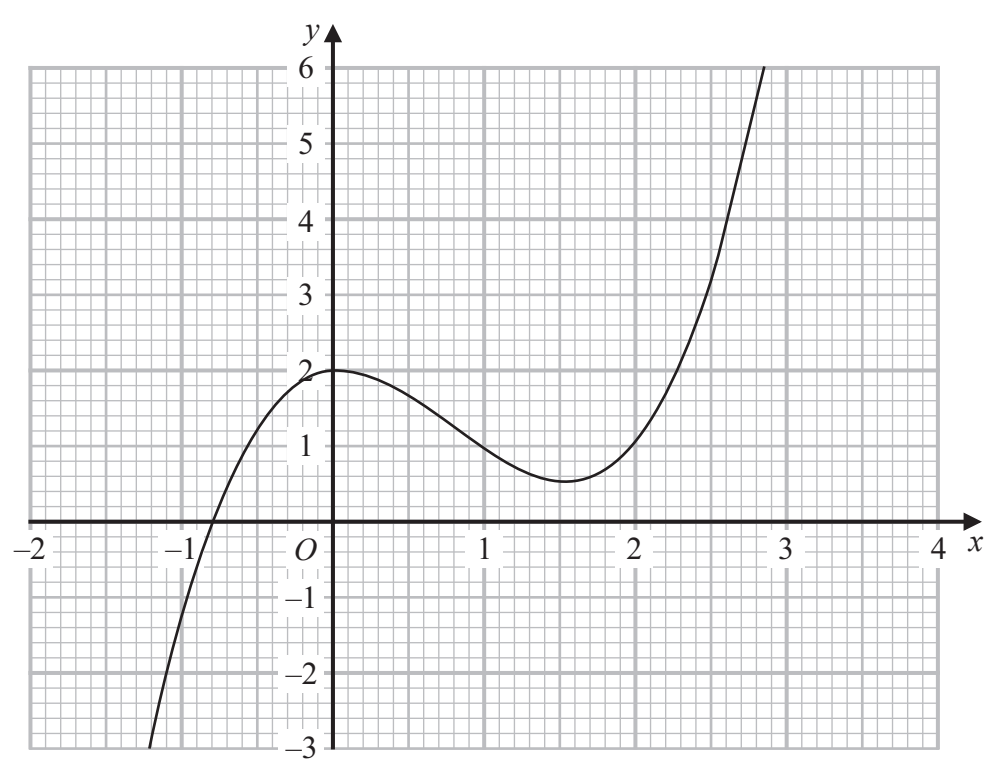

DO NOT WRITE IN THIS AREA

DO NOT WRITE IN THIS AREA

DO NOT WRITE IN THIS AREA

Find an estimate for the gradient of the curve at the point where $x = 2$
Show your working clearly.

.....
(Total for Question 17 is 3 marks)



18 The line with equation $2y = x + 1$ intersects the curve with equation $3y^2 + 7y + 16 = x^2 - x$ at the points A and B

Find the coordinates of A and the coordinates of B
Show clear algebraic working.

DO NOT WRITE IN THIS AREA

DO NOT WRITE IN THIS AREA

DO NOT WRITE IN THIS AREA

(.....,) and (.....,)

(Total for Question 18 is 5 marks)



19 $ABCD$ is a horizontal rectangular field.

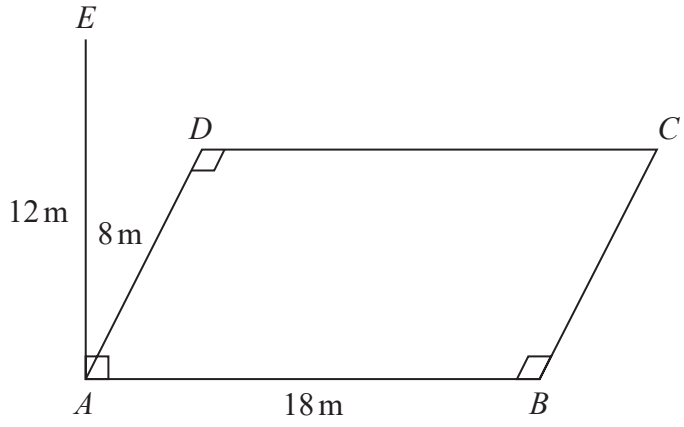

Diagram **NOT** accurately drawn

A vertical pole, AE , is placed at the corner A of the field.

$$AE = 12\text{ m} \quad AB = 18\text{ m} \quad AD = 8\text{ m}$$

Calculate the size of the angle between EC and the plane $ABCD$
Give your answer correct to one decimal place.

DO NOT WRITE IN THIS AREA

DO NOT WRITE IN THIS AREA

DO NOT WRITE IN THIS AREA

(Total for Question 19 is 3 marks)



20 y is inversely proportional to \sqrt{x}
 x is directly proportional to T^3

Given that $y = 8$ when $T = 25$

find the exact value of T when $y = 27$

DO NOT WRITE IN THIS AREA

DO NOT WRITE IN THIS AREA

DO NOT WRITE IN THIS AREA

$T = \dots\dots\dots$

(Total for Question 20 is 4 marks)



- 21 The diagram shows a solid made from a cylinder and a hemisphere.
The cylinder and the hemisphere are both made from the same metal.

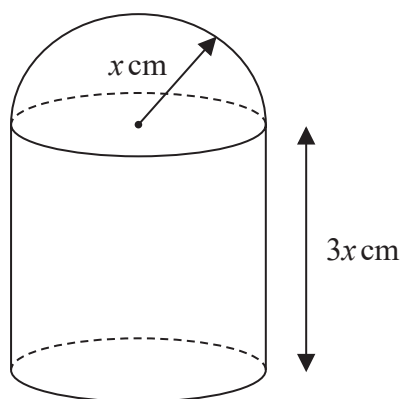

Diagram **NOT** accurately drawn

DO NOT WRITE IN THIS AREA

DO NOT WRITE IN THIS AREA

DO NOT WRITE IN THIS AREA

The plane face of the hemisphere coincides with the upper plane face of the cylinder.

The radius of the cylinder and the radius of the hemisphere are both x cm.
The height of the cylinder is $3x$ cm.

The total surface area of the solid is $81\pi\text{cm}^2$
The mass of the solid is 840 grams.

The following table gives the density of each of four metals.

Metal	Density (g/cm^3)
Aluminium	2.7
Nickel	8.9
Gold	19.3
Silver	10.5

The metal used to make the solid is one of the metals in the table.

Determine the metal used to make the solid.
Show your working clearly.



DO NOT WRITE IN THIS AREA

DO NOT WRITE IN THIS AREA

DO NOT WRITE IN THIS AREA

.....
(Total for Question 21 is 6 marks)

Turn over for Question 22



22 ABC is a triangle in which angle $ABC = 90^\circ$

p and q are integers such that

the coordinates of A are $(p, 10)$

the coordinates of B are $(-1, -5)$

the coordinates of C are $(8, q)$

Given that the gradient of AC is $-\frac{6}{7}$

work out the value of p and the value of q



DO NOT WRITE IN THIS AREA

DO NOT WRITE IN THIS AREA

DO NOT WRITE IN THIS AREA

$$p = \dots\dots\dots$$

$$q = \dots\dots\dots$$

(Total for Question 22 is 5 marks)

Turn over for Question 23



23 The functions f and g are such that

$$f(x) = x + 25 \qquad g(x) = x^2 - 12x$$

The function h is such that $h(x) = fg(x)$

The domain of h is $\{x : x \leq 6\}$

Express the inverse function h^{-1} in the form $h^{-1}(x) = \dots$

$$h^{-1}(x) = \dots\dots\dots$$

(Total for Question 23 is 4 marks)

TOTAL FOR PAPER IS 100 MARKS

DO NOT WRITE IN THIS AREA

DO NOT WRITE IN THIS AREA

DO NOT WRITE IN THIS AREA



DO NOT WRITE IN THIS AREA

DO NOT WRITE IN THIS AREA

DO NOT WRITE IN THIS AREA

BLANK PAGE



DO NOT WRITE IN THIS AREA

DO NOT WRITE IN THIS AREA

DO NOT WRITE IN THIS AREA

BLANK PAGE

